

Step-Thru

Assembly Instructions



Platform - Safety Rail Assembly

Platform - Safety Rail Assembly

IMPORTANT: To avoid assembly problems follow these instructions exactly.

Step 1 - Fasten the two piece Side Safety Rail Set together at A using an M6 x 40mm Bolt and Nyloc Nut. Repeat for the second rail. (See illustration No. 1)

Step 2 - Attach one Side Safety Rail to the Rear Brace Plate with two M6 x 40mm Bolts and Nyloc Nuts at B and C. Position the Rear Brace Plate so that it wraps around the Safety Rail on the inside. (See illustration No. 2)

Step 3 - Position the Platform and Side Safety Rail as shown and slide the front of the Side Safety Rail into the Platform Kickrail housing at position D. Fix the rear of the Safety Rail to the Platform Kickrail. Use a 6 x 45mm "PATCH-LOK" bolt and screw in with the hexagon key - *Leaving bolt slightly loose*. (See illustration No. 3)

Note: Do NOT use Pnuematic or Electric drivers with Patch-Lok Fixings

Step 4 - Pass a 6 x 40mm bolt through the top hole at the front of the Platform Kickrail and fit a nut . *Finger tight only*. (See illustration No. 4)

Step 5 - Repeat steps 2, 3 and 4 and fit the remaining Side Safety Rail.

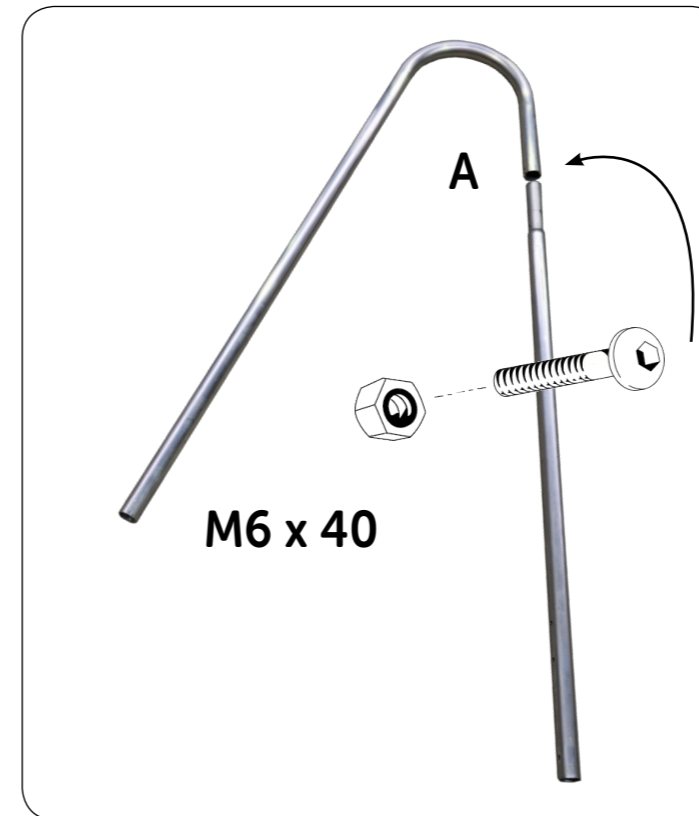

Illustration 1

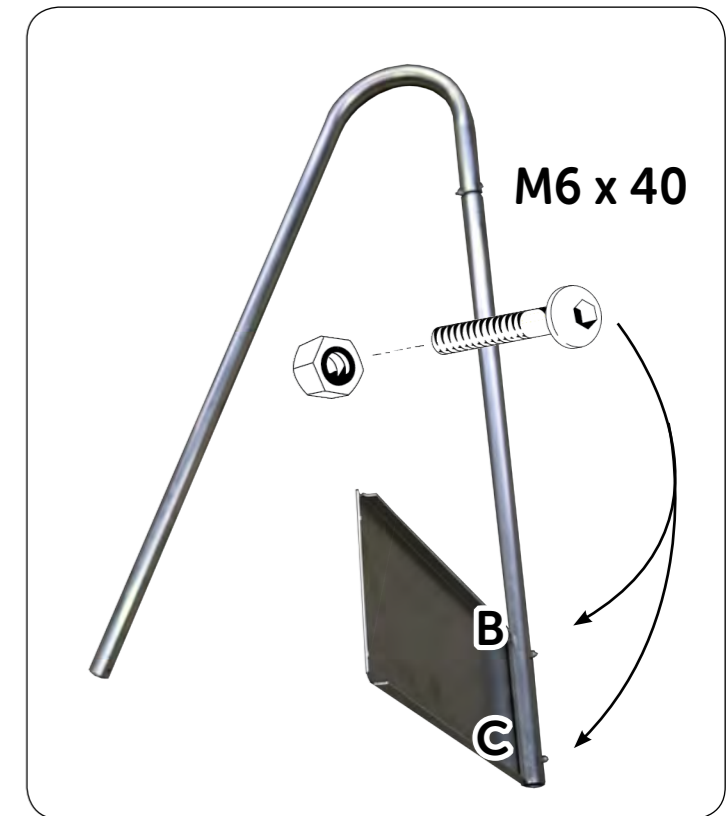

Illustration 2

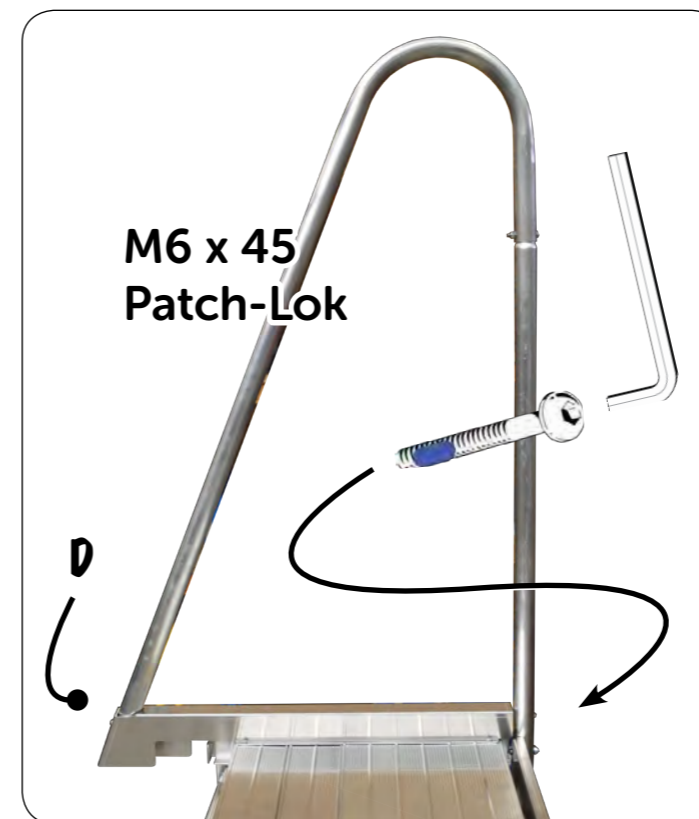

Illustration 3



Illustration 4

Ladder Frame Assembly

Ladder Frame Assembly

IMPORTANT: To avoid assembly problems follow these instructions exactly. Work Safely - Do not stand the frames upright when assembling. Place the frames in the positions as shown in the illustrations.

Step 1 - Lay the Rear Frame (without steps) on the floor and place the Platform over the frame as shown. Check that the side with the Flat Brace "E" is face side down. (See illustration No. 1)

Step 2 - Fix the Tube Brace, Platform and Rear Frame together using a 10 x 20mm bolt and nut - *finger tight only*. For ease, lift the Frame up slightly. Repeat the process and fit the remaining Tube Brace. (See illustration No. 2)

Step 3 - Turn the Platform on its side. Place something under the Platform Rails as illustrated so the centre line of the Rear Frame is approximately parallel to the floor. The long box may be used for this. (See illustration No. 3)

Step 4 - Engage the Front Frame (with steps) into the Platform and fix together using a 10 x 20mm bolt and nut - *finger tight only*. For ease, lift the Frame up slightly. Repeat this step for the other side.. (See illustration No. 4)

Step 5 - Fix the free ends of the Tube Braces to the Front Frame using 10 x 20mm bolts and nuts - *finger tight only*. Do not tighten the 10mm bolts until advised. (See illustration No. 5)



Illustration 2



Illustration 3

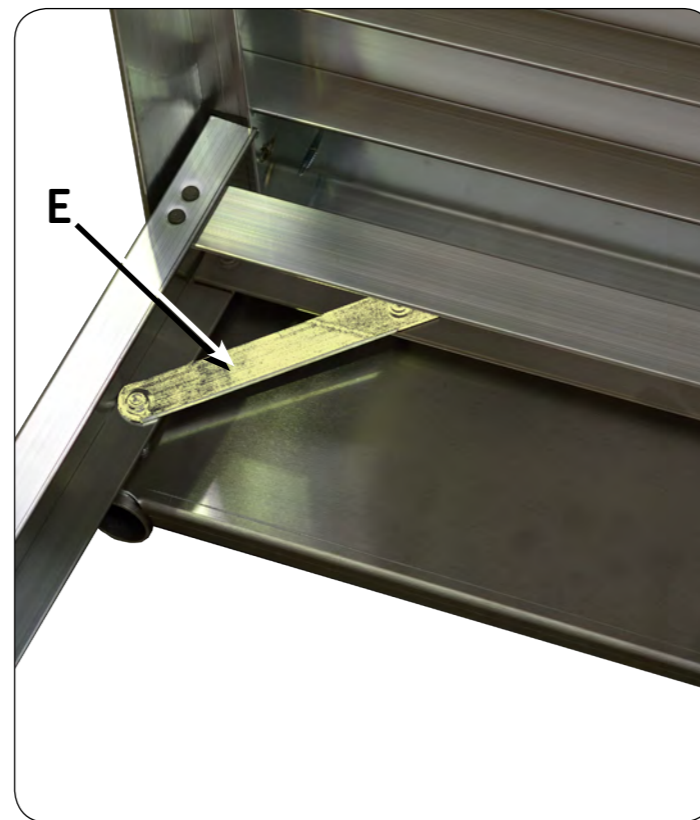

Illustration 1



Illustration 4



Illustration 5

Tube Brace Assembly

IMPORTANT: To avoid assembly problems follow these instructions exactly. Work Safely - Do not stand the frames upright when assembling. Place the frames in the positions as shown in the illustrations.

Instructions for sizes with 3 to 7 steps including the platform:

There are no additional Tube Braces to be fitted to these sizes. Proceed to Control Handle Assembly

Instructions for sizes with 8 to 10 steps including the platform:

See Steps 1 & 2 only

Step 1 - Place the Ladder on its side and place something under the Platform as illustrated so the centre line of the Rear Frame is approximately parallel to the floor. The Mobilisation carton may be used for this. (See illustration No. 1)

Step 2 - Remove the 4 off, M10 x 20 bolts and nuts from the Tube Braces packaged within the framset and Discard these Tube Braces. (See illustration No. 2).

Note: The correct length Tube Braces for sizes 8 to 10 are packaged in the Mobilisation carton. Open this carton and retrieve these parts now.

Step 3 - Fix one of the two Tube Braces to the Frame at A and B using the M10 x 20 bolts and nuts from step 2 above. Turn the Ladder over and fit the other Brace. - *Finger tight only. Do not tighten the M10 bolts until advised.* (See illustration No. 3).

Tube Brace Assembly



Illustration 1

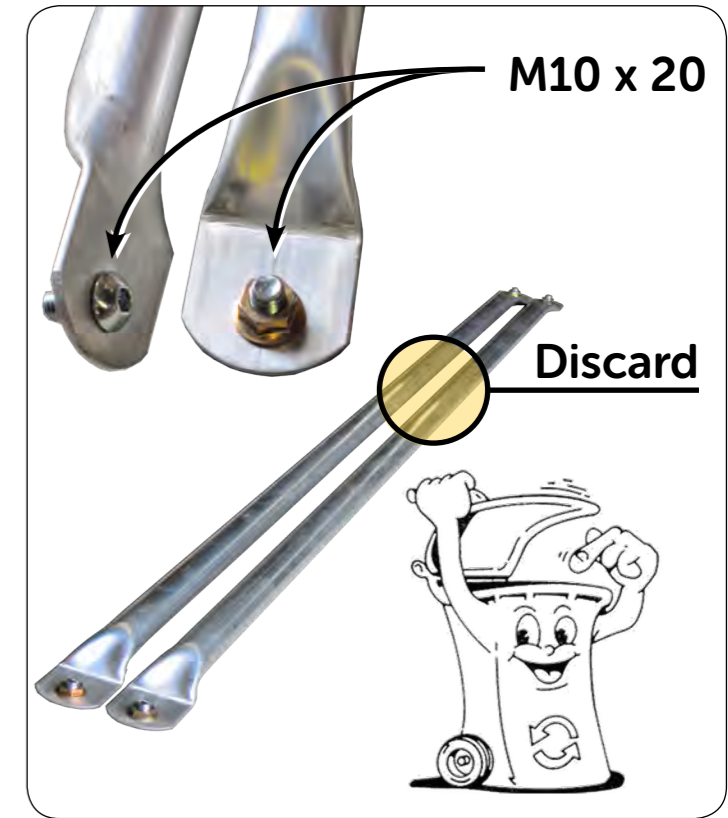

Illustration 2

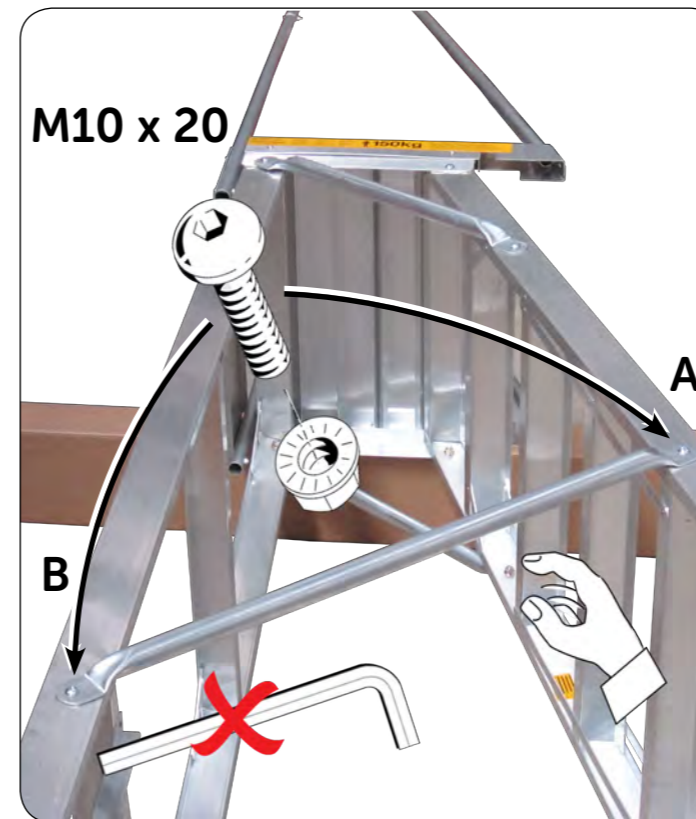

Illustration 3

Control Handle Assembly

IMPORTANT: To avoid assembly problems follow these instructions exactly. Work Safely - This assembly is done with the Stockmaster standing upright.

Step 1 - Stand the Ladder upright. Position the Control Handle in the Step Frame between the 2nd and 3rd steps. (See illustration No. 1)

Step 2 - Fix the Control Handle to the Frame. Pass an "E" Pin through the hole in the Control Handle and the Upper hole in the Mounting Angle of the Step Frame. (See illustration No. 2)

Step 3 - Secure with an "E" Clip fitted to the outside ring of the "E" Pin. (See illustration No. 3)



Illustration 1

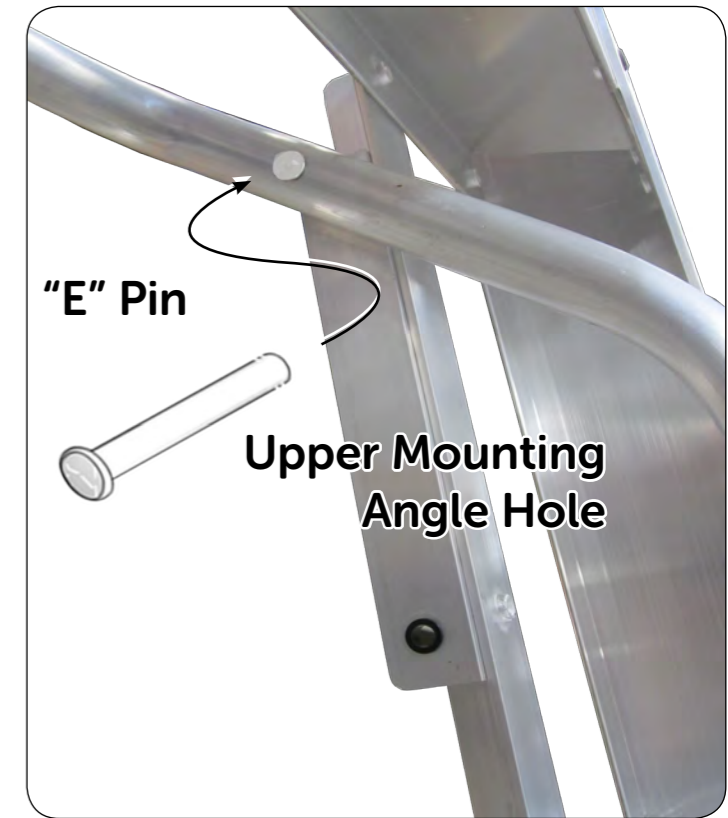

Illustration 2



Illustration 3

Handrail Assembly

Handrail Assembly

IMPORTANT: To avoid assembly problems follow these instructions exactly. Work Safely - This assembly is done with the Stockmaster standing upright.

Step 1 - Fix the Handrail to the Platform Kickrail. Slide the Handrail into the Kickrail and rotate the handrail so that the lower end is over the Step. Place an M6 x 40 bolt through the bottom hole at the front of the Kickrail and fit a nut *Finger tight only.* (See illustration No. 1)

Step 2 - Fix the Handrail to the Step. Place an M6 x 40 bolt through the Handrail and fit the nut under the Step. Check that the Handrails are correctly aligned and tighten all four bolts using the Hex Key and Double Ended Spanner. (See illustration No. 2)

Step 3 - Illustration No. 3 shows completed Handrail assembly.

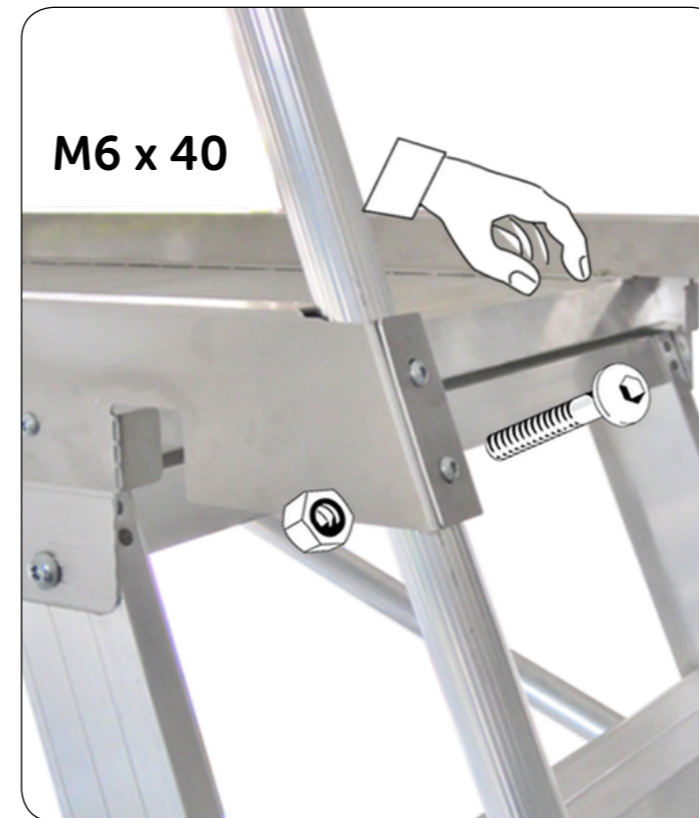

Illustration 1



Illustration 2



Illustration 3

Mobilisation Assembly

IMPORTANT: To avoid assembly problems follow these instructions exactly. Work Safely - Do not stand the frames upright when assembling. Place frames in the positions shown in the illustrations

Step 1 - Fix the Mobilisation Rails (Rectangular Hollow Section - RHS) to the Frames at A & B. The fixing detail is shown in steps 2 to 3 (See illustration No. 1)

Step 2 - Fix the Mobilisation Rails to the Rear Frame at A. Use a 12 x 65mm Bolt, Nylon Sleeve, Large Nylon Spacer and Nyloc Nut. Pass the Bolt thru the Frame and fit the Large Nylon Spacer and Nylon Sleeve. (See illustration No. 2)

Step 3 - Fit the Mobilisation Rail over the Nylon Sleeve and secure with the 12mm nut. Ensure the Sleeve is properly seated within the Mobilisation RHS section - *Finger tight only*. Fix the Mobilisation Rail to the Front Frame at B repeating the above procedure. Fix the second Mobilisation Rail to the opposite side in the same manner. (See illustration No. 3)

Step 4 - Fit the Rubber Bump Stop to the Anti-Tilt Plate as shown using the 6 x 35 screw and nyloc nut. Place the Anti-Tilt Plate and 12mm Washer over the end of the Mobilisation RHS as shown and align the holes. (See illustration No. 4)

Note: This item is a Safety Feature to prevent accidental overturning and must be fitted.

Step 5 - Fit a Washer to the 12 x 110mm Hex Bolt. Place the Wheel Bearing C inside the Wheel and pass the bolt thru the bearing. Place the Wheel over the Anti-Tilt Plate and pass the bolt thru the Washer, Anti-Tilt Plate and Mobilisation RHS (See illustration No. 5)

Step 6 - Slide the Nylon Sleeve over the Bolt and insure it properly seats within the Mobilisation RHS. Fit the 12mm Nut and tighten. Repeat steps 4-6 for the other side. (See illustration No. 6)

Step 7 - Stand the Ladder upright on a level surface. Stand on the first step taking hold of ladder frame and flexing it so both the feet and wheels sit firmly on the floor. When there is no evidence of rocking, tighten the four Mobilisation to Frame fixings using the Hex Key and Spanner provided. Now tighten the remaining 10mm bolts in the Ladder Frames using the Hex Key only. (*Hold the nut in a fixed position with the spanner. Do not rotate the nut.*)

Mobilisation Assembly

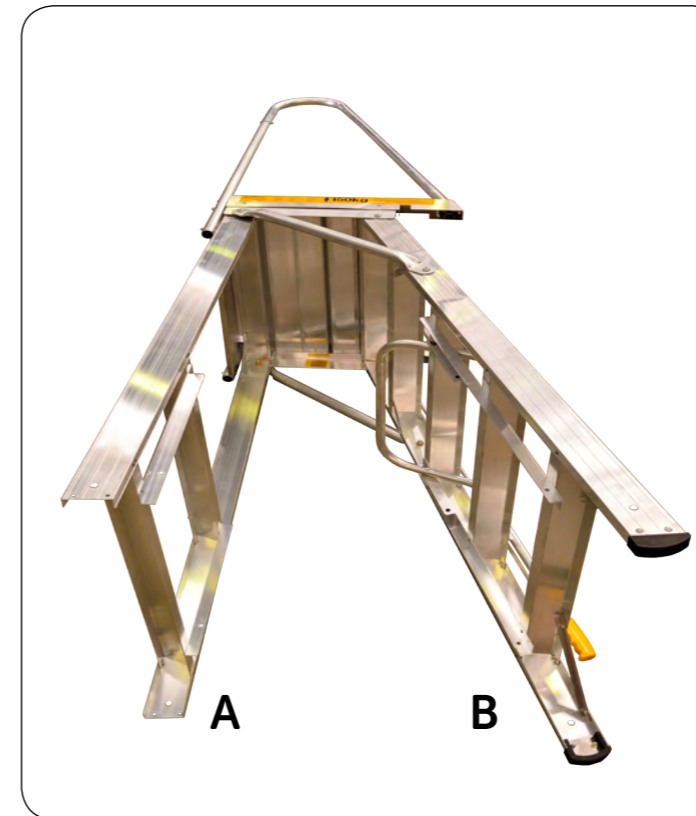

Illustration 1

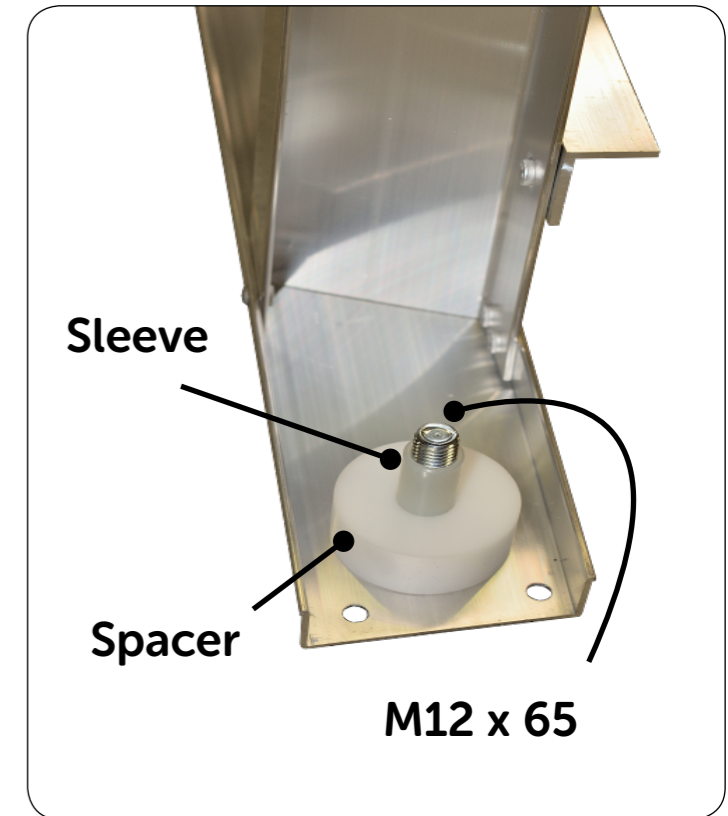

Illustration 2

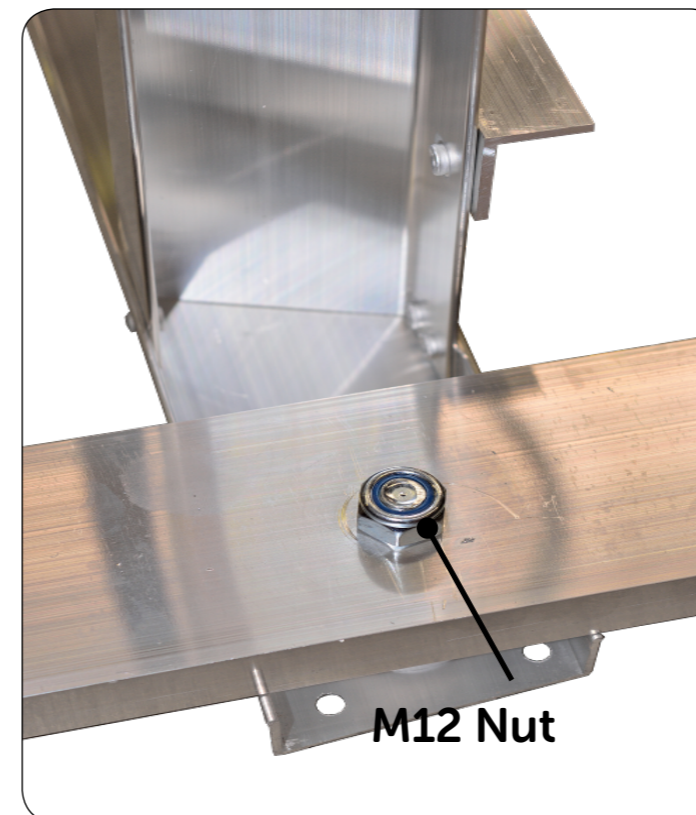

Illustration 3

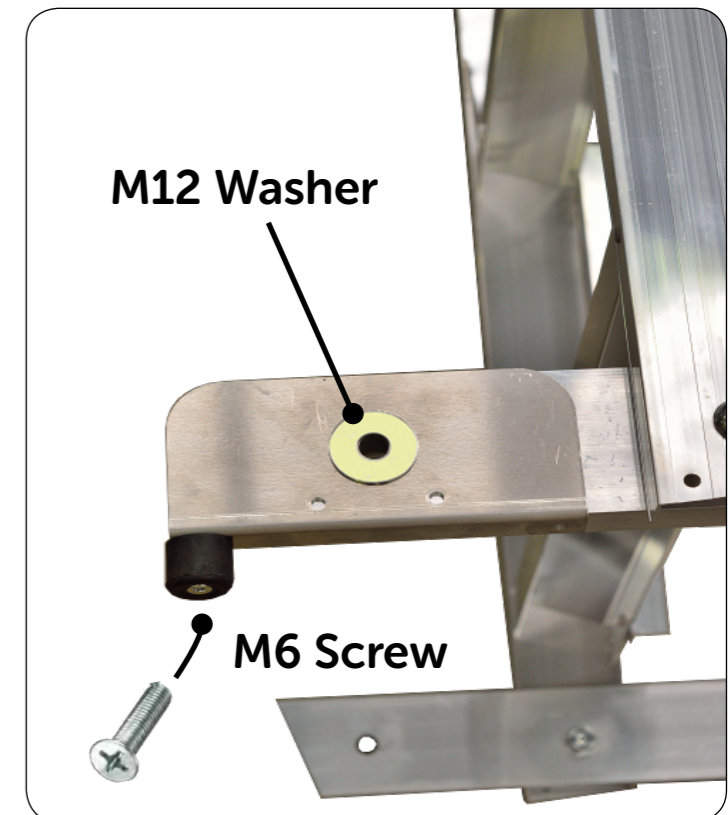

Illustration 4

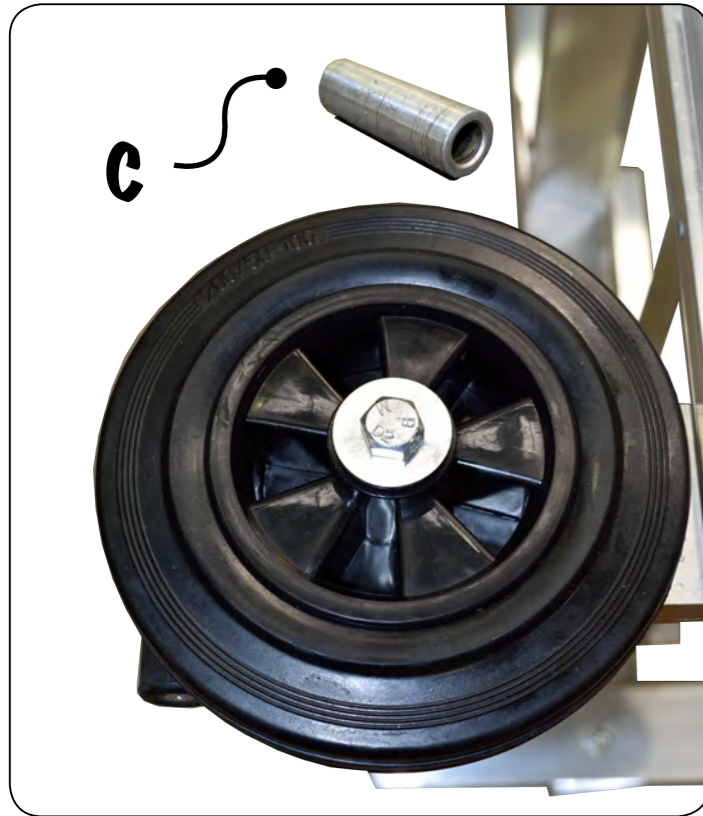

Illustration 5



Illustration 6