

## Mezzalift

Assembly  
Instructions



# Mast Assembly

# Mast Assembly

**IMPORTANT:** To avoid assembly problems follow these instructions exactly.

**Step 1** - On a level surface butt the two Mast sections together. (See illustration No. 1)

**Step 2** - Fix the Large Mast Joining Plate to the two Mast sections using four of the M6 x 16 button head screws - *Finger tight only*. (See illustration No. 2)

**Step 3** - Turn the Mast over. Locate the Small Mast Joining Plates and position them inside the Mast channel and fasten using four of the M6 x 16 button head screws. Ensure Mast sections are correctly aligned and then tighten all screws. (See illustration No. 3)

**Step 4** - Lift the Mast as shown cut and remove the Wire Tie then lay the Mast flat on its back again. (See illustration No. 4)

**Step 5** - In the centre of the Mast Channel. Cut and remove the Black Wire Ties holding the chain bundle in position. (See illustration No. 5)

**Note:** Do NOT cut the White Wire Tie.

**Step 6** - Using the White Wire Tie. Pull the stored chain down the length of the mast until taught. (See illustration No. 6)

**Step 7** - Loosen the Mast Roller at the base of the Mast (See illustration No. 7)

**Step 8** - Using the 2 Black Wire Ties supplied. Tie the chain to the top of the Mast thru the holes A & B. Ensure the White Wire Tie is located between these two tie positions. (See illustration No. 8)

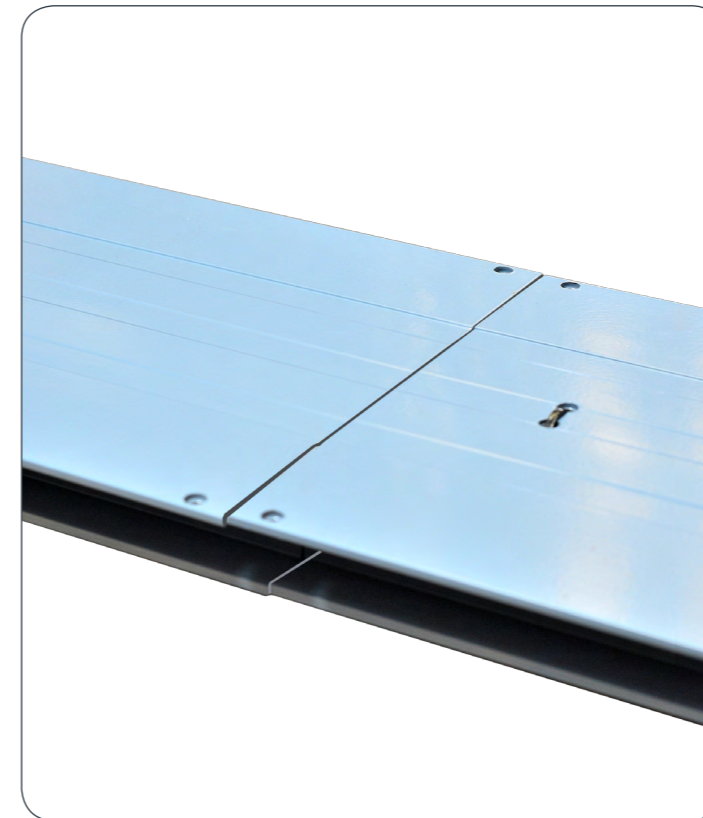

Illustration 1

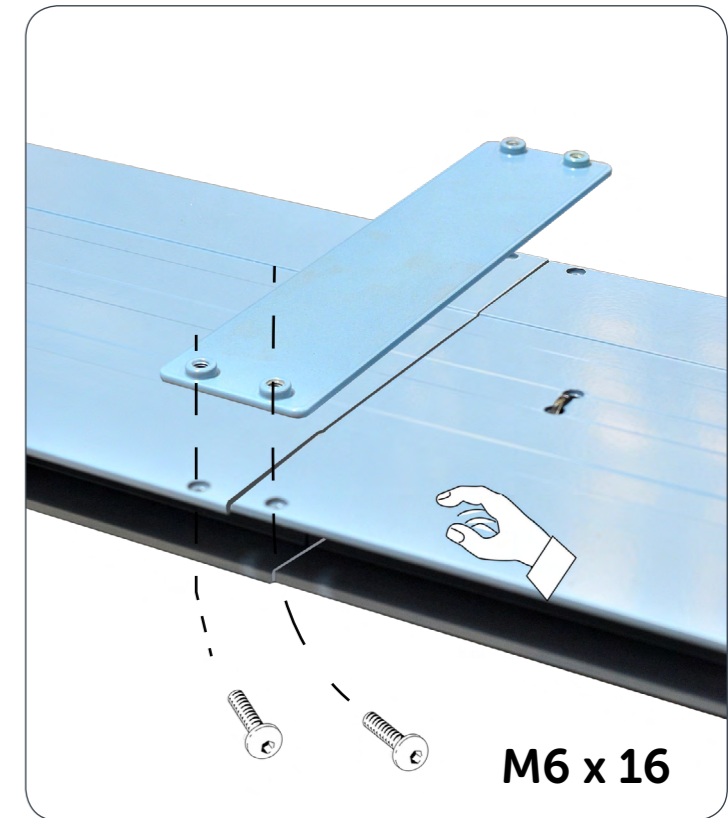

Illustration 2

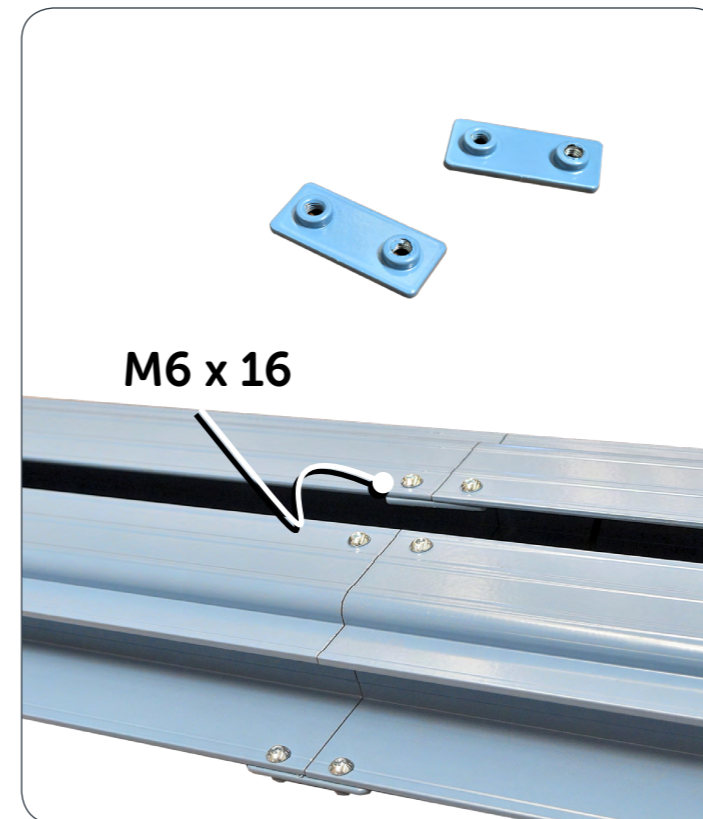

Illustration 3



Illustration 4



Illustration 5

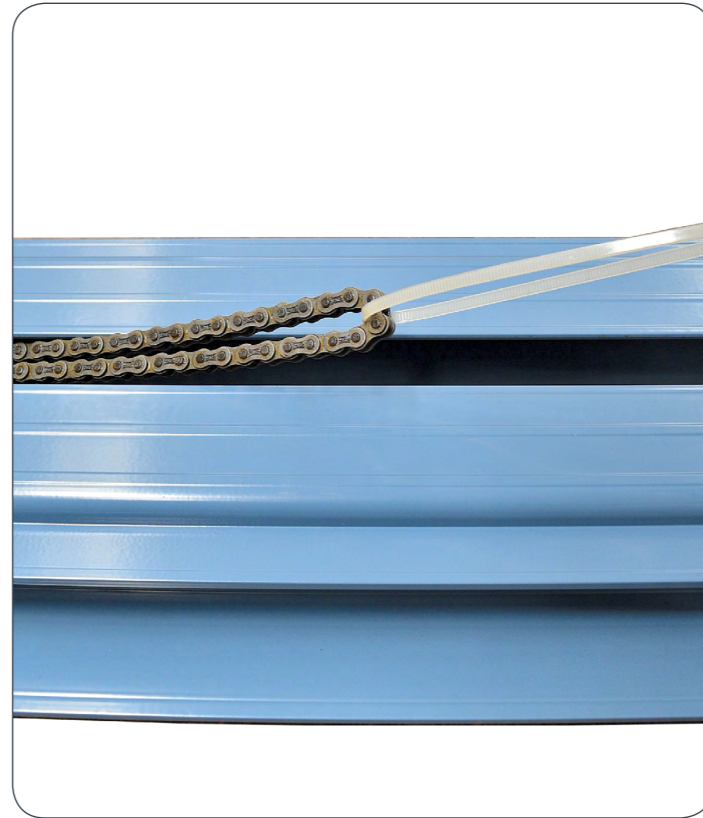

Illustration 6



Illustration 7

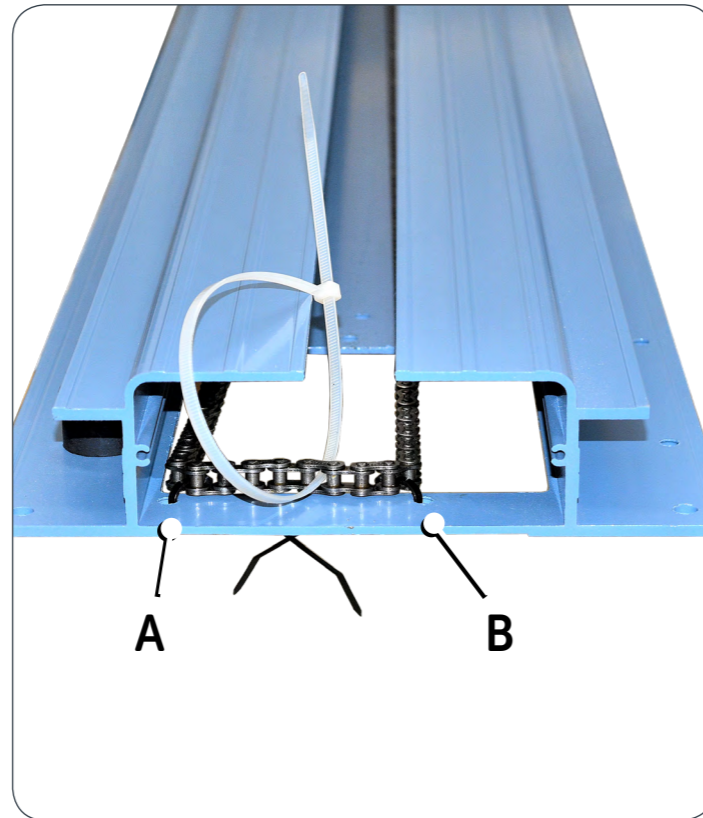

Illustration 8

# Winch Assembly

# Winch Assembly

**IMPORTANT:** To avoid assembly problems follow these instructions exactly.

**Step 1** - On a level surface lay the mast face-down as shown. (See illustration No. 1)

**Step 2** - Remove the Nut from the Winch Shaft at A. Pull out the winch shaft and remove the Sprocket. Carefully put the Sprocket, Shaft, Nut & Washer aside. Parts to be re-assembled in Step 4. (See illustration No. 2)

**Step 3** - Place the Winch Body inside the opening on the back of the Mast. Insert the Winch Body at 45 degrees so the Chain fits inside the Winch Body. (See illustration No. 3)

**Step 4** - Fix the Winch Mounting Bracket to the Mast at B & C using two of the M6 x 16 button head screws and nyloc nuts. *Finger tight only.* (See illustration No. 4)

**Step 5** - Adjust the Winch Mounting Bracket so you can slide the Sprocket back into place. Insert the Winch Shaft at D and re fit the washer and nut. Fix the Winch Mounting Bracket to the Mast at E using an M6 x 16 button head screw and nyloc nut. Tighten the Winch Shaft and nut firmly then tighten the Winch Mounting Bracket screws and nuts at B, C, & E (See illustration No. 5)



Illustration 2



Illustration 3

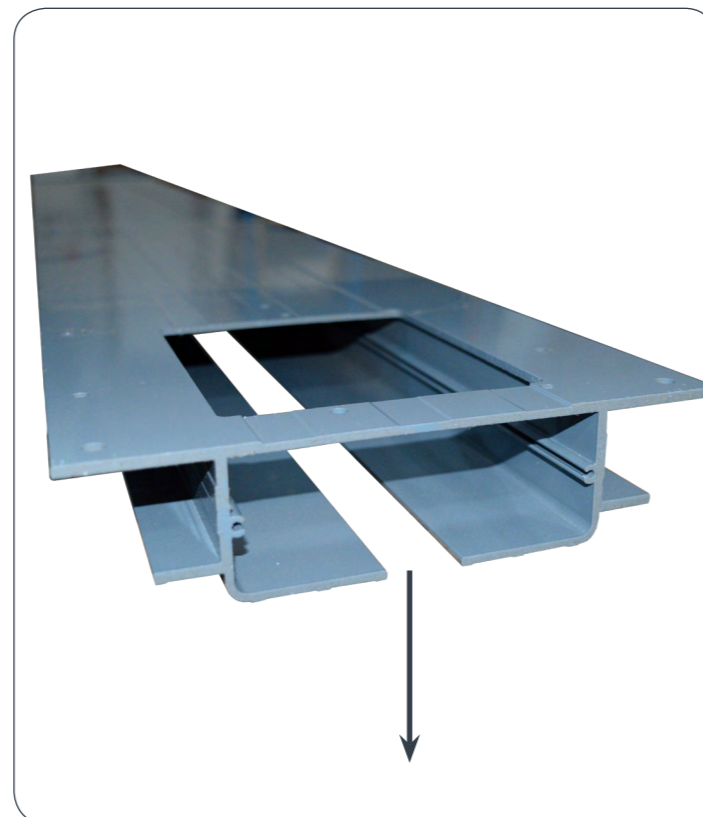

Illustration 1

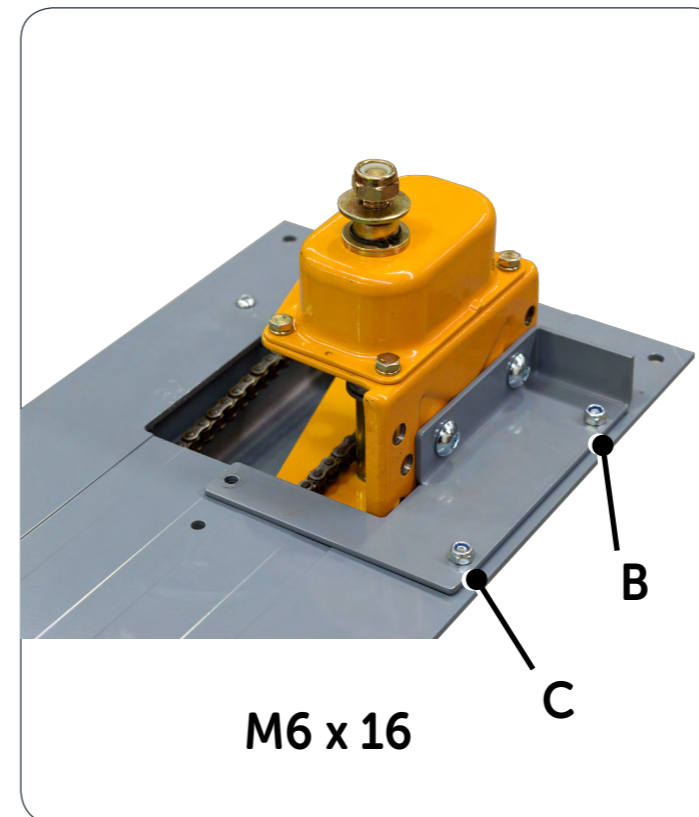

Illustration 4

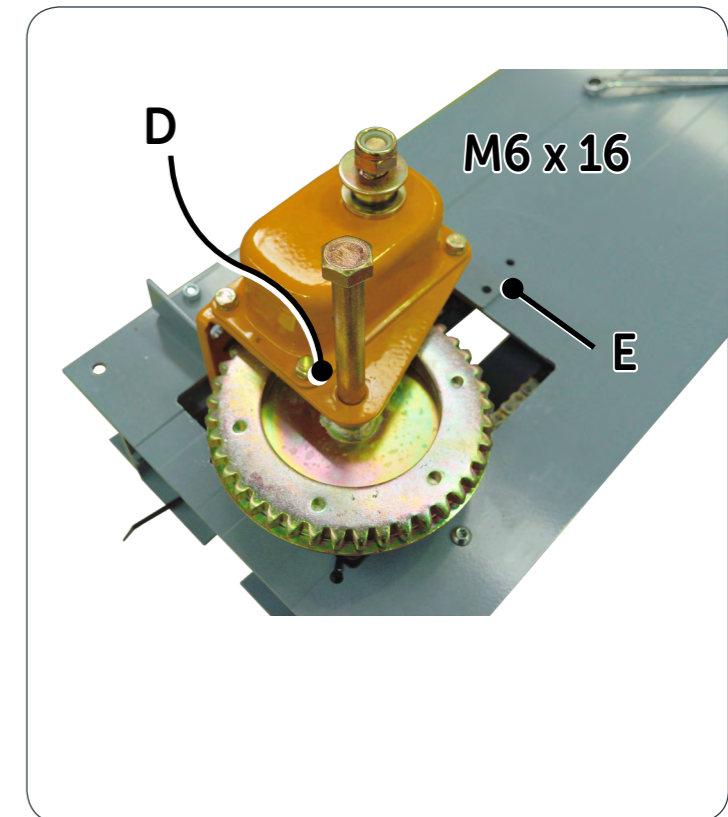

Illustration 5

# Mounting Bracket Assembly

# Mounting Bracket Assembly

**IMPORTANT:** To avoid assembly problems follow these instructions exactly.

**Step 1** - Fit the upper Floor Support Angle to the Mast at A & B as shown using two of the M8 x 20 button head screws and nyloc nuts. Screws facing up. Nuts on top. (See illustration No. 1)

**Note:** Upper Floor Support Angle can be fitted upside down on the Mast if required for additional height adjustment.

**Step 2** - Fit the Mast Cradle Bracket to the bottom of the Mast at C using an M6 x 16 button head screw and nyloc nut. (See illustration No. 2)

**Step 3** - Fix the two Upright Sections to the Base Bracket using four of the M8 x 20 button head screws and nyloc nuts. *Finger tighten only.* (See illustration No. 3)

**Step 4** - Measure the Vertical Height from the Lower Floor level to the Upper floor level at the position the Mezz-a-lift is to be installed. (See illustration No. 4)

**Step 5** - Position the Base Assembly over the Mast Cradle Bracket. Measure the total length from the upper Floor Support Angle to the bottom of the Base Assembly. Adjust the position of the base assembly to reflect the measurement from Step 4. (See illustration No. 5)

**Step 6** - Fix the Base Assembly to the Mast Cradle Bracket, thru the fixing slots on both sides of the Upright Sections using four of the M8 x 20 button head screws and nyloc nuts. *Finger tighten only.* (See illustration No. 6)

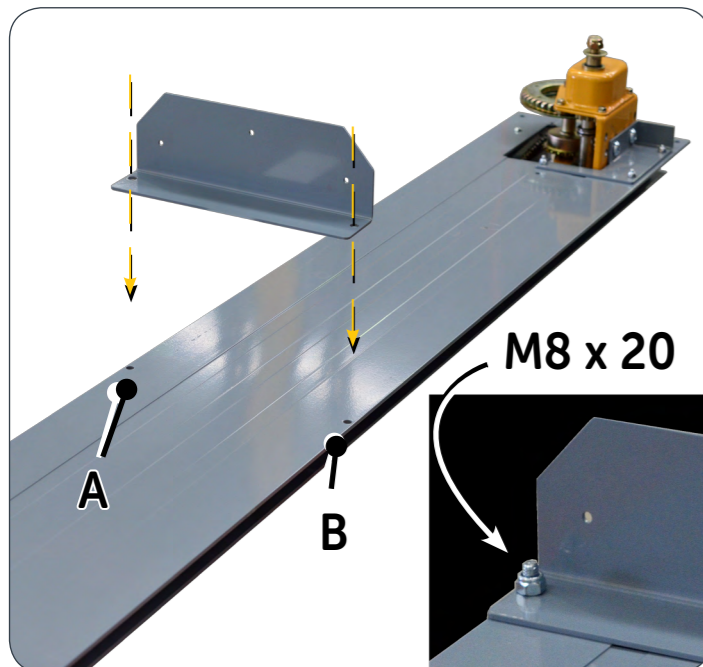

Illustration 1

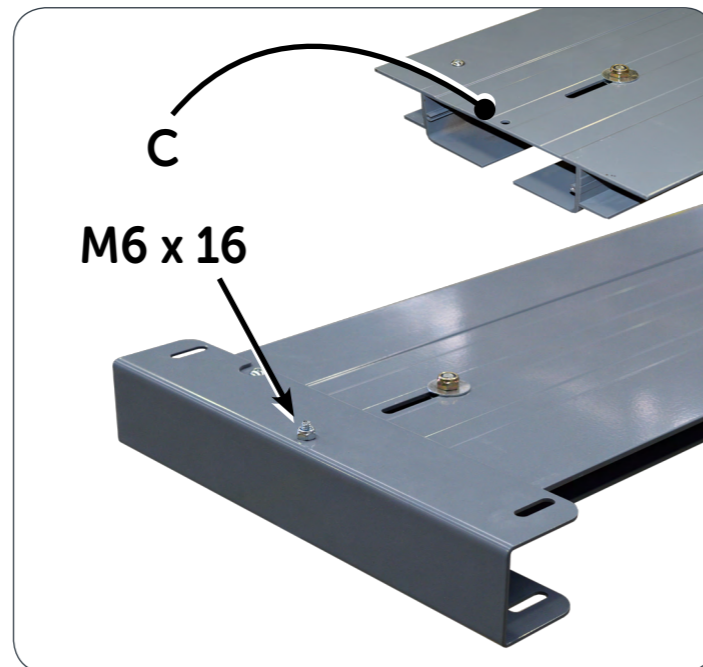

Illustration 2



Illustration 3



Illustration 4



Illustration 5

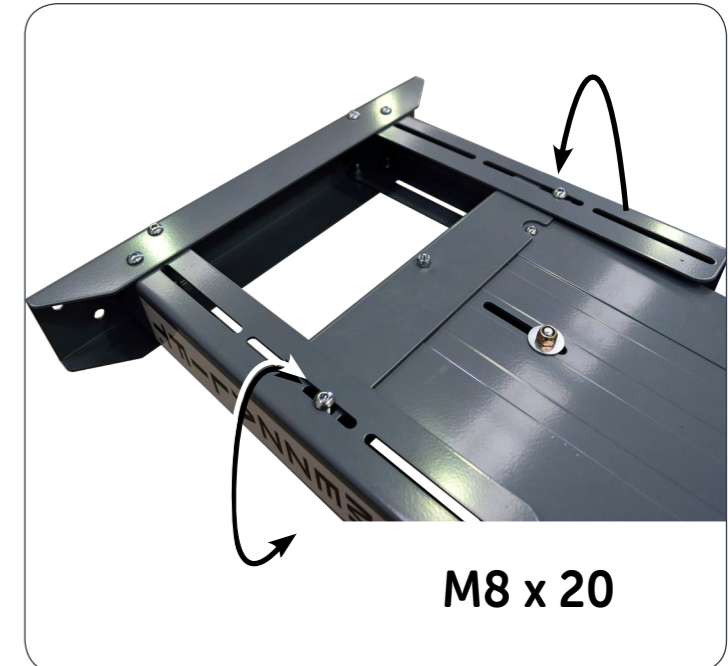

Illustration 6

# Installation

**IMPORTANT:** To avoid assembly problems follow these instructions exactly.

**Step 1** - Stand the Mezz-a-Lift into position placing the upper Floor Support Angle on the upper landing in the required position. With someone supporting the unit, mark the fixing positions A1 - A3 in the upper landing thru the Floor Support Angle. Drill and fix at these locations with appropriate fixings. *Fixings not supplied* (See illustration No. 1)

**Step 2** - Using a Spirit Level, level the Mezz-a-Lift front to rear and side to side (See illustration No. 2)

**Step 3** - Mark the fixing positions B1 - B4 in the lower floor thru the Base Bracket. Drill and fix at these locations with appropriate fixings. *Fixings not supplied* (See illustration No. 3)

**Step 4** - Tighten *ALL* fasteners now

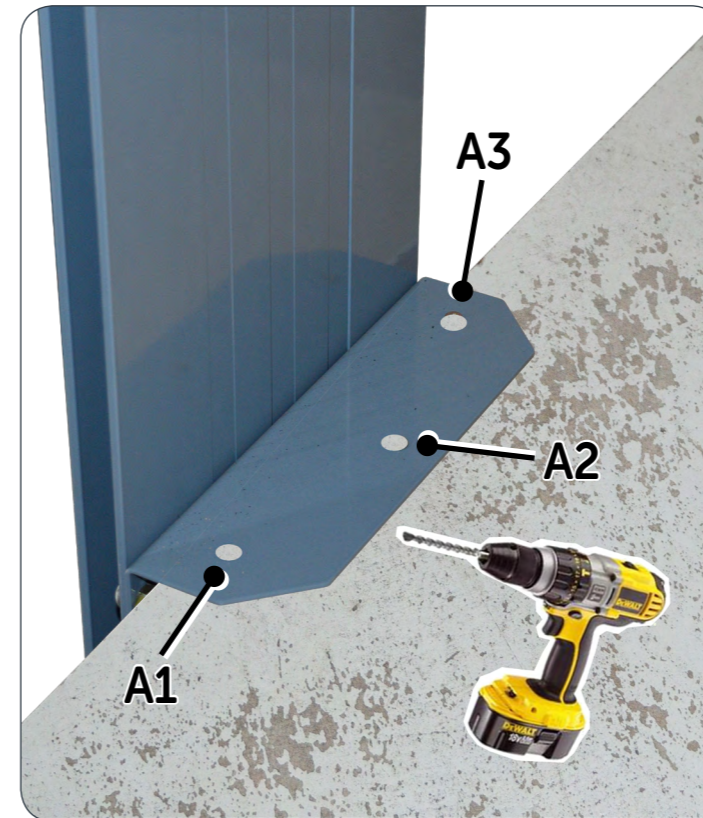

Illustration 1



Illustration 2

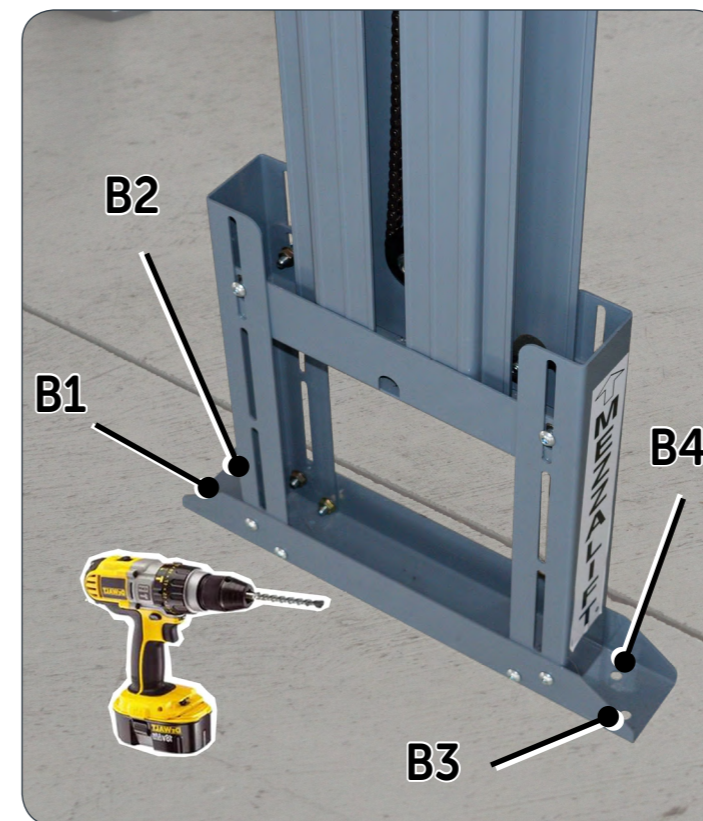

Illustration 3

**Tighten  
ALL Fasteners  
at this point**

# Chain Setting

# Chain Setting

**IMPORTANT:** To avoid assembly problems follow these instructions exactly.

**Step 1** - Cut and remove the **Black Wire Ties** at the top of the Mast. Do not cut the **Large White Centre Tie** (See illustration No. 1)

**Step 2** - Position the Chain around the Sprocket using the **Large White Wire Tie**. Once the Chain is engaged correctly, cut and remove the **Wire Tie**. (See illustration No. 2)

**Step 3** - Slide the Chain Roller toward the bottom of the Mast to tension the Chain. Check that the Chain is engaged with the roller and tighten the screw and nut. (See illustration No. 3)

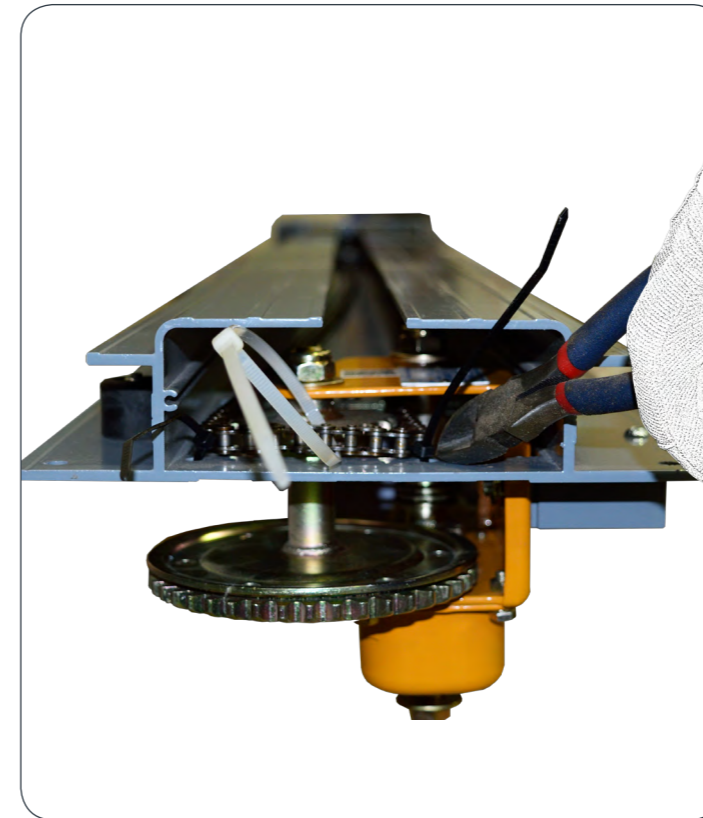

Illustration 1

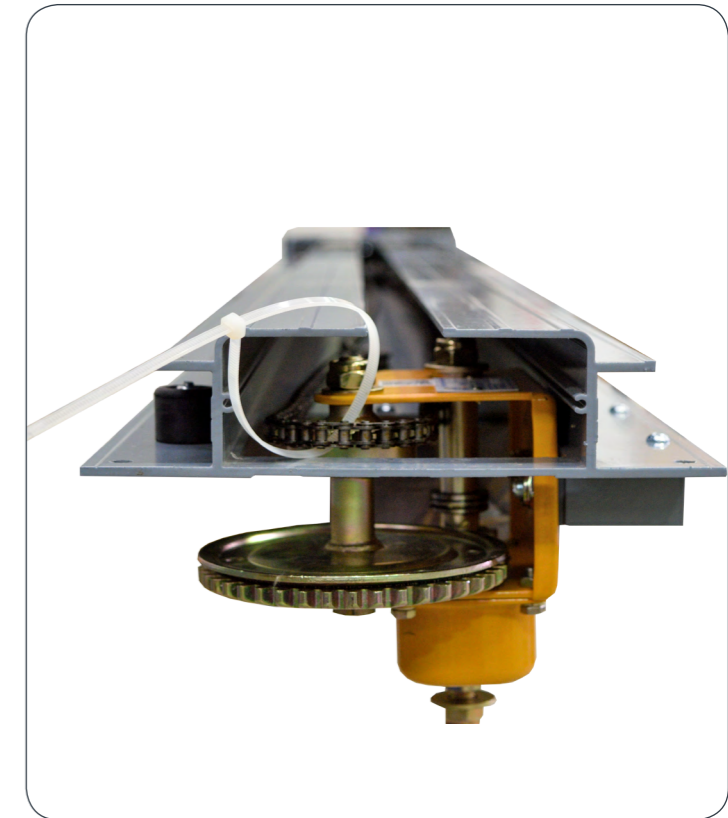

Illustration 2

**NEXT:** Proceed to Winch Cover & Handle Assembly

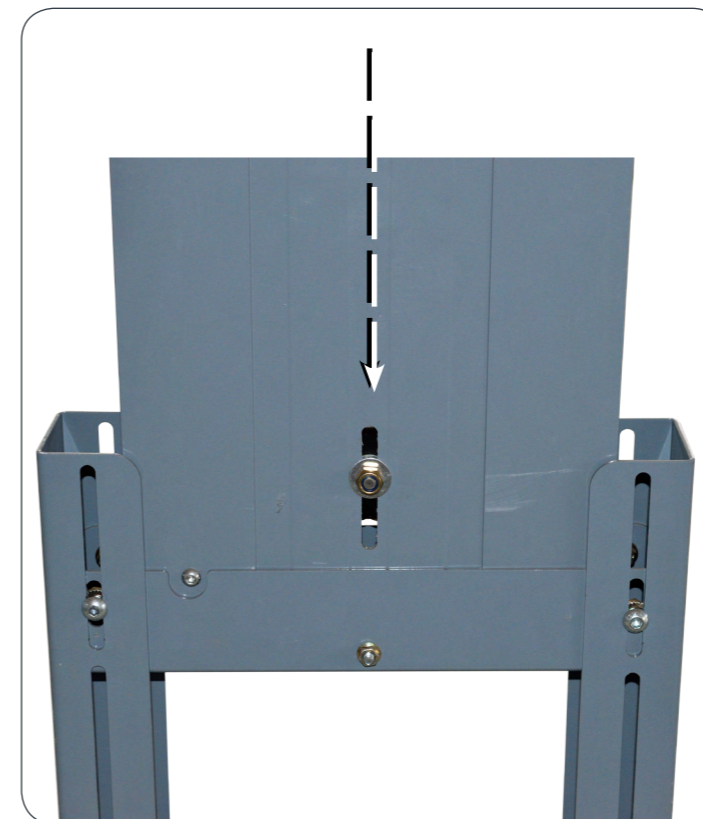

Illustration 3

# Installing the Winch Cover & Handle

# Installing the Winch Cover & Handle

**IMPORTANT:** To avoid assembly problems follow these instructions exactly.

**Step 1** - Place the Winch Cover over the Winch. Fix the top of the cover to the C slots of the Mast using the Self Tapping Screws at A and B. (See illustration No. 1)

**Step 2** - Fix the bottom flange of the Winch Cover at C to the Mast with an M6 x 16mm bolt and nyloc nut. Fix the Winch Handle, Washer and nyloc nut to the Winch shaft and tighten. (See illustration No. 2)

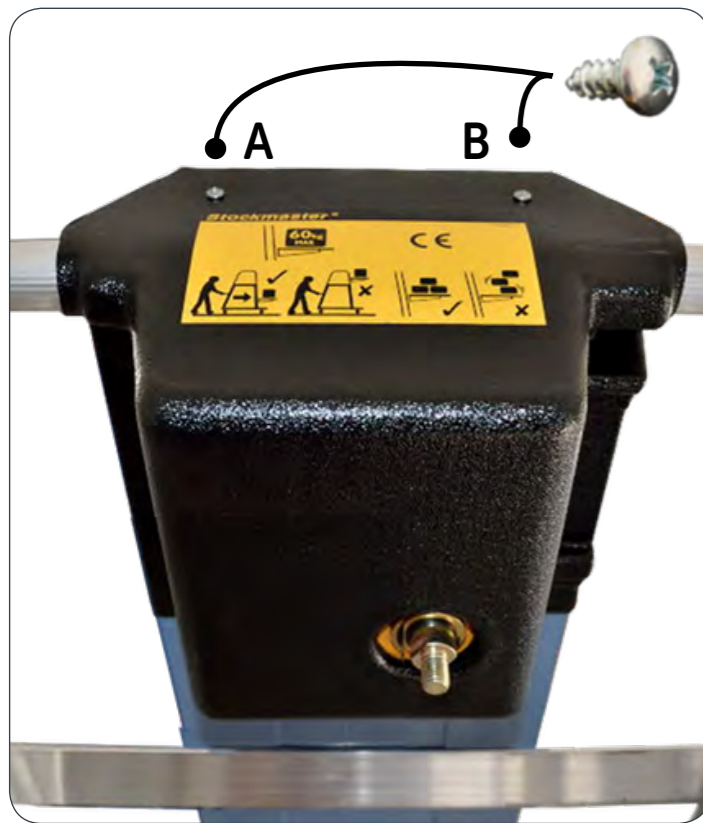

Illustration 1

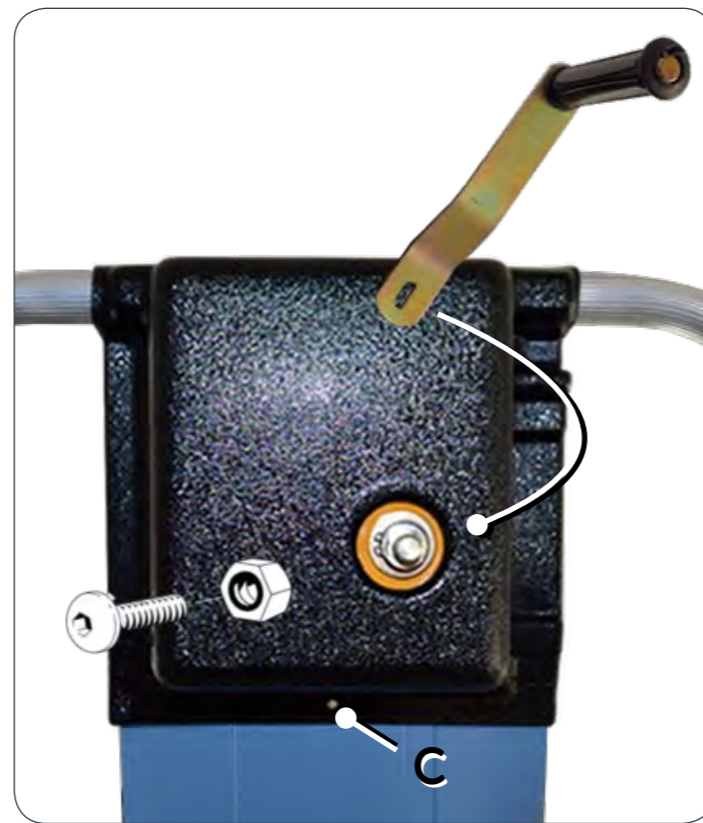

Illustration 2

# Lift Table Assembly

**IMPORTANT:** To avoid assembly problems follow these instructions exactly.

**Step 1** - Position the Carriage Rollers of the Upper and Lower Table Brackets within the side track of the Mast. (See illustration No. 23)

**Step 2** - Fix the Upper Table Bracket to the top hole in the Mast Carriage using the M10 x 20mm bolts and nyloc nuts. Repeat for the other side. *Leave bolts slightly loose.* (See illustration No. 24)

**Step 3** - The Lower Table Brackets can be fitted to the Mast Carriage at one of 2 positions. The Upper hole in the Mast Carriage is for Lift-Truk models and the Lower hole is for Mezzalift. Using the M10 x 20mm bolts and nyloc nuts, Fix the Lower Table Brackets to the Mast Carriage at the hole position relative to your model. *Leave bolts slightly loose.* (See illustration No. 25)

**Step 4** - Fix the Lift Table to the Table Brackets using the M6 x 25mm bolts and nyloc nuts. Tighten the nuts and then tighten the Table Bracket to Mast Carriage bolts. (See illustration No. 26)



Illustration 23



Illustration 24

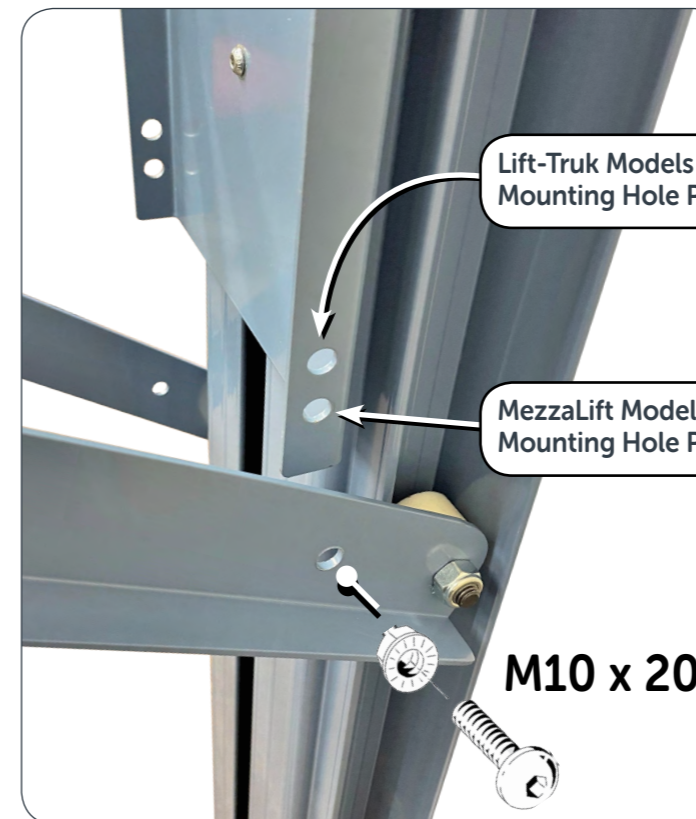

Illustration 25

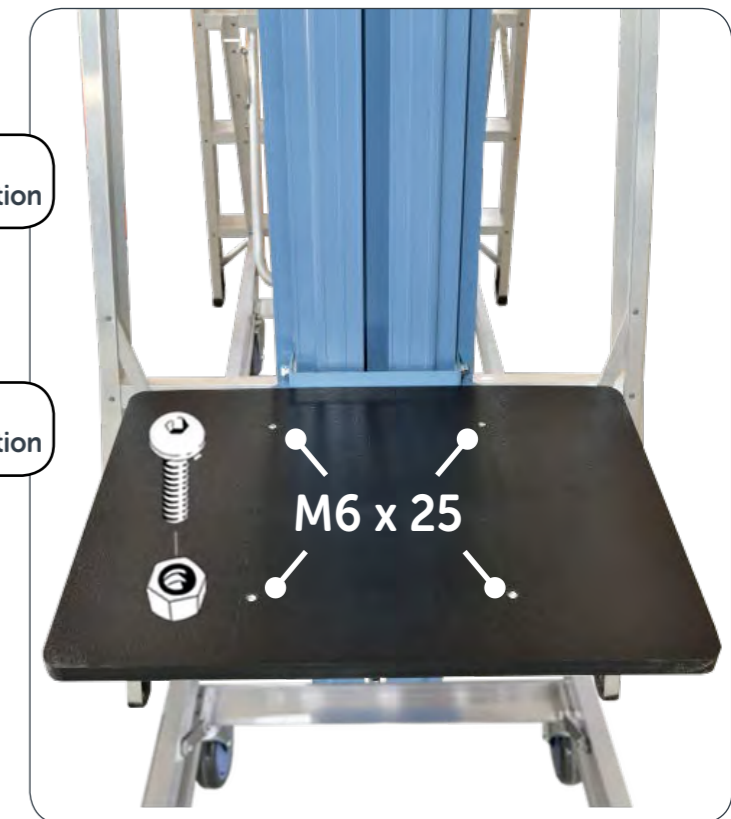

Illustration 26

**IMPORTANT:** To avoid assembly problems follow these instructions exactly.

**Step 1** - Assemble the two Side Safety Barrier fences to the Front Safety Barrier Fence with four M6 x 65 button head screws and nyloc nuts. (See illustration No. 1)

**Step 2** - With the Lift Table wound all the way to the bottom of the Mast, position the Safety Barrier Fence so it clears the Lift Table on all sides. Mark the fixing positions thru the Bottom Flanges in the Safety Barrier Fence Kickrails. Drill and fix at these locations with suitable fixings. *These fixings not supplied* (See illustration No. 2)

**IMPORTANT:** Test the unit before use. Place a minimum load of 20kg on the Lift Table and Raise the Lift Table up approximately half a meter. The Table must not move when the Winch Handle is released. If the Table moves, DO NOT USE and contact your supplier for instructions.

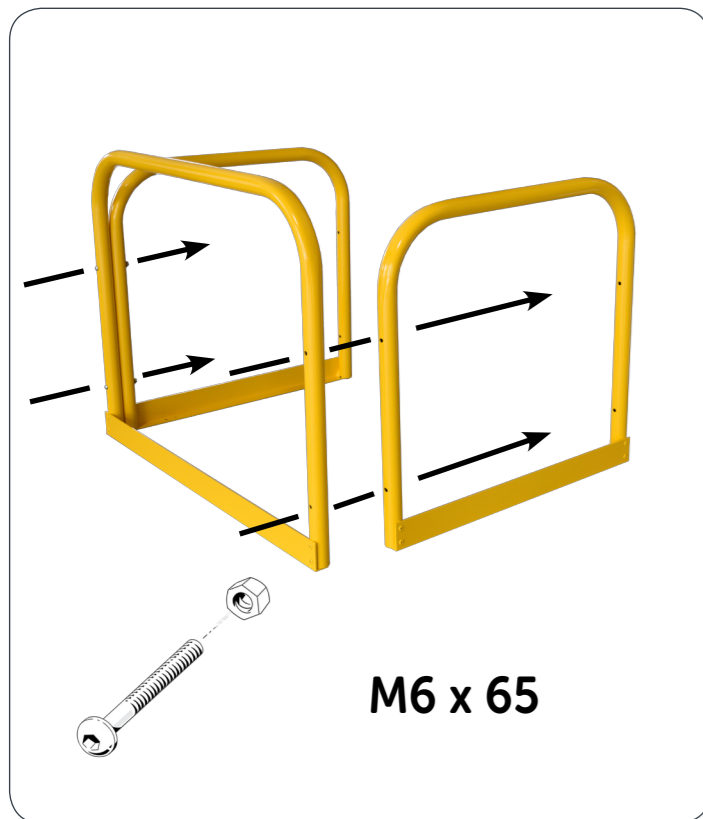

Illustration 1

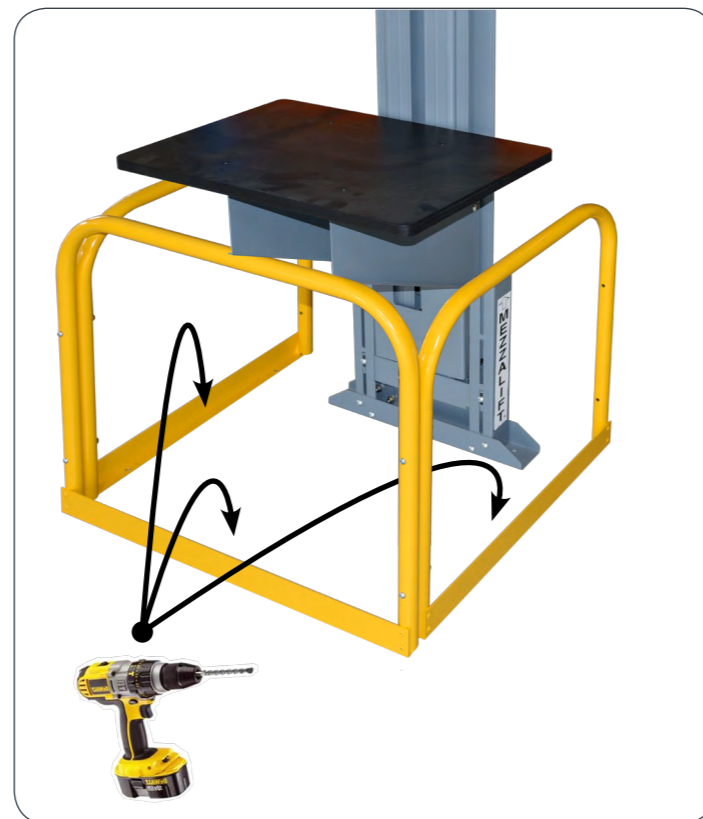

Illustration 2